Intermediate frequency amplifier

SPECIFICATION

1 FEATURES

- SMIC CMOS 0.18 μm
- Wide gain range (0...62 dB)
- Low input noise figure
- Low group delay time ripple vs. frequency and gain
- Digital and analog output modes
- Built-in AGC detector without external capacitor
- No external components required
- Portable to other technologies (upon request)

2 APPLICATION

- Receivers
- Transceivers
- Navigation systems

3 OVERVIEW

The device is a dual intermediate-frequency amplifier (IFA) which consists of 4 stages amplifier with tunable gain, an input linear buffer for analog output and an analog-digital converter for digital output and a detector of output level.

The amplifier has differential inputs and outputs, and consists of 4 stages. Gain is sequentially reduced from the last stage to the first stage. This method allows to keep a low noise figure in wide gain range.

The amplifier can operate in the following modes:

- linear output with automatic gain control (AGC)
- digital output with AGC for analog signal
- digital output with AGC for digital signal

In the analog output mode the circuit retains a low output offset voltage and controls the gain so that the magnitude of the differential output signal is 200 mV peak-to-peak. DC offset compensation system operates both at an amplifier output signal and at a buffer output signal.

Digital output with AGC for analog signal mode operates similarly to the previous mode, through the output signal is converted by ADC. 2-bit ADC consists of three comparators (a one registers "0", the rest operate at certain positive and negative threshold crossing). Encoder is used to transmit signals from the three comparators, through two outputs. The encoder has outputs SIGN and MAGN

In the digital output with AGC for digital signal mode compensation system uses zero transient comparator signal (SIGN). AGC operates in an automatic control mode of digital detector threshold for digital signal (MAGN). Threshold and gain are set by the DAC code.

The block is fabricated on SMIC CMOS 0.18 μm technology.

4 STRUCTURE

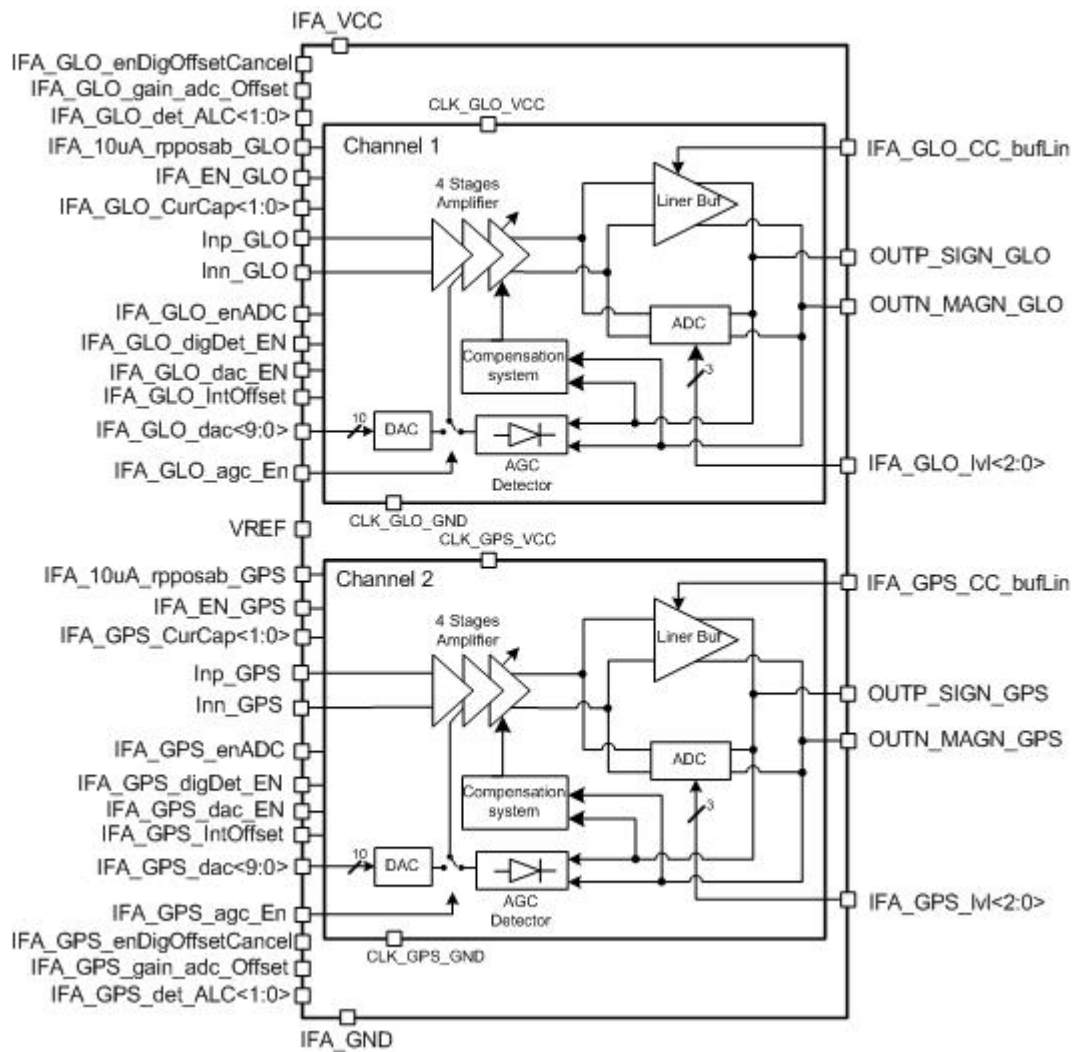

Figure 1: Intermediate frequency amplifier structure

5 PIN DESCRIPTION

Name	Direction	Description
VREF	I	Reference voltage
IFA_VCC	IO	Supply voltage 1.8 V
IFA_GND	IO	Ground
Channel 1 IFA pin description		
IFA_10uA_rpposab_GLO	I	Reference current 10 uA
Inp_GLO	I	Analog differential input
Inn_GLO	I	
OUTPUT_SIGN_GLO	O	Analog/digital differential output
OUTPUT_MAGN_GLO	O	
IFA_EN_GLO	I	IFA enable/disable
IFA_GLO_enADC	I	ADC mode enable
IFA_GLO_agcEN	I	AGC mode enable
IFA_GLO_digDet_EN	I	Digital detector enable
IFA_GLO_dac_EN	I	DAC enable
IFA_GLO_IntOffset	I	DC output voltage offset compensation enable
IFA_GLO_lvl<2:0>	I	ADC comparator level adjustment
IFA_GLO_dac<9:0>	I	Digital code for IFA gain control or AGC control
IFA_GLO_CurCap<1:0>	I	Speed capability adjustment of digital and analog AGC
IFA_GLO_CC_bufLin	I	Linear buffer mode
IFA_GLO_enDigOffsetCancel	I	Digital DC voltage offset compensation enable
IFA_GLO_gain_adc_Offset	I	Offset compensation system adjustment
IFA_GLO_det_ALC<1:0>	I	AGC level commutation
CLK_GLO_VCC	IO	Digital supply voltage
CLK_GLO_GND	IO	Digital ground
Channel 1 IFA pin description		
IFA_10uA_rpposab_GPS	I	Reference current 10 uA
Inp_GPS	I	Analog differential input
Inn_GPS	I	
OUTPUT_SIGN_GPS	O	Analog/digital differential output
OUTPUT_MAGN_GPS	O	
IFA_EN_GPS	I	IFA enable/disable
IFA_GPS_enADC	I	ADC mode enable
IFA_GPS_agcEN	I	AGC mode enable
IFA_GPS_digDet_EN	I	Digital detector enable
IFA_GPS_dac_EN	I	DAC enable
IFA_GPS_IntOffset	I	DC output voltage offset compensation enable
IFA_GPS_lvl<2:0>	I	ADC comparator level adjustment
IFA_GPS_dac<9:0>	I	Digital code for IFA gain control or AGC control
IFA_GPS_CurCap<1:0>	I	Speed capability adjustment of digital and analog AGC
IFA_GPS_CC_bufLin	I	Linear buffer mode
IFA_GPS_enDigOffsetCancel	I	Digital DC voltage offset compensation enable

Table "Pin description" (continue)

Name	Direction	Description
IFA_GPS_gain_adc_Offset	I	Offset compensation system adjustment
IFA_GPS_det_ALC<1:0>	I	AGC level commutation
CLK_GPS_VCC	IO	Digital supply voltage
CLK_GPS_GND	IO	Digital ground

6 LAYOUT DESCRIPTION

The block dimensions are given in the table 1.

Table 1: Block dimensions

Dimension	Value	Unit
Height	980	um
Width	1695	um

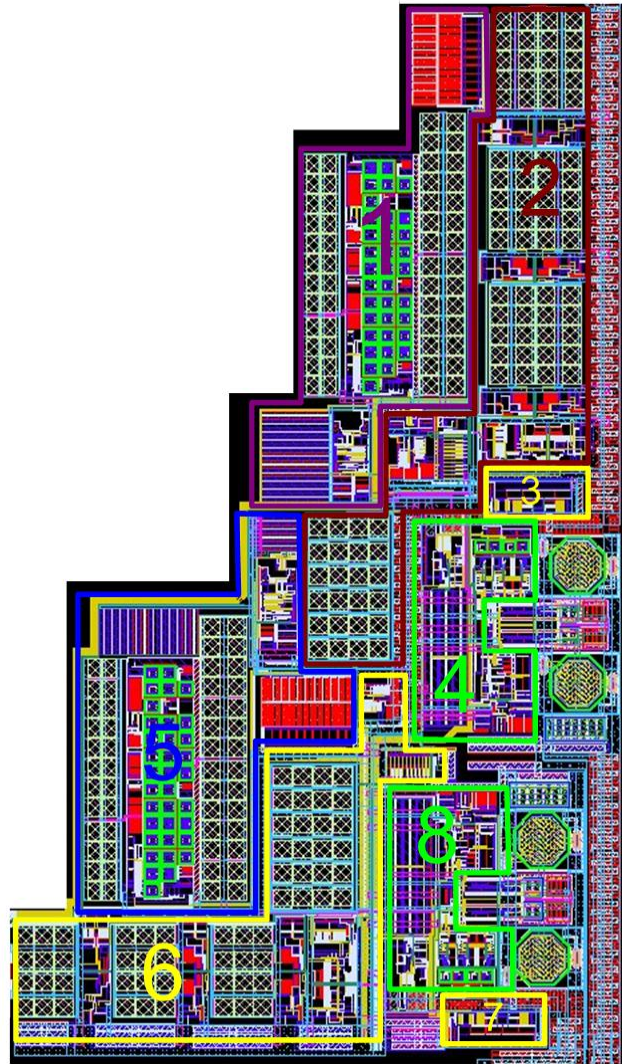

Figure 2: Intermediate frequency amplifier layout

1. Detector (Channel 1)
2. IFA core (Channel 1)
3. Linear buffer (Channel 1)
4. ADC (Channel 1)
5. Detector (Channel 2)
6. IFA core (Channel 2)
7. Linear buffer (Channel 2)
8. ADC (Channel 2)

7 OPERATING CHARACTERISTICS

7.1 TECHNICAL CHARACTERISTICS

Technology _____ SMIC CMOS 0.18 um
 Status _____ silicon proven
 Area _____ 1.1 mm²

7.2 ELECTRICAL CHARACTERISTICS

The values of electrical characteristics are specified for $V_{cc} = 1.7 \div 1.9$ V and $T_j = -45 \div +85$ °C. Typical values are at $V_{cc} = 1.8$ V and $T_j = +27$ °C, unless otherwise specified.

Parameter	Symbol	Condition	Value			Unit
			min	typ.	max	
Supply voltage	V_{cc}	-	1.7	1.8	1.9	V
Operating temperature range	T_j	-	-45	27	85	°C
Frequency range	F	-	7	-	20	MHz
Noise figure	NF_{IFA}	Maximum gain mode	-	6.5	9.4	dB
		At 30 dB less than maximum amplification	-	6.8	9.8	dB
Group delay time ripple	t_{del}	Bandwidth 7...20 MHz	-	1.8	-	ns
Gain	G_{IFA}	-	0	-	62	dB
Input impedance	R_{in}	-	-	2	-	kOhm
Output impedance	R_{out}	IFA_GLO_CC_bufLin = "1"	-	-	260	Ohm
		IFA_GLO_CC_bufLin = "0"	-	-	320	
Peak-to-peak differential output voltage	$A_{in\ p-p}$	2pF load, sin signal: OUTPUT_SIGN_GLO, OUTPUT_MAGN_GLO – For channel 1; OUTPUT_SIGN_GPS, OUTPUT_MAGN_GPS – For channel 2	-	200	-	mV
DC voltage	V_{IFA_dif}	Linear mode: for OUTPUT_SIGN_GLO, OUTPUT_MAGN_GLO – For channel 1; OUTPUT_SIGN_GPS, OUTPUT_MAGN_GPS – For channel 2	-	1.46	-	V
ADC resolution	K	-	-	2	-	bit
ADC output signal level	V_{dig}	Preset 1	-	1.0	-	V
		Preset 2		1.2		
		Preset 3		1.5		
		Preset 4		1.8		
Current consumption	I_{cc}	Linear mode	-	3.1	3.7	mA
	I_{dig}	Digital mode	-	3	-	
Stand-by current	I_{stb}	-	-	15	1800	nA
Output logic-level high (digital output)	V_{OH_dig}	OUTPUT_SIGN_GLO, OUTPUT_MAGN_GLO – For channel 1; OUTPUT_SIGN_GPS, OUTPUT_MAGN_GPS For channel 2	$V_{dig} - 100$	-	-	mV

Table “Electrical characteristics” (continue)

Parameter	Symbol	Condition	Value			Unit
			min	typ.	max	
Output logic-level low (digital output)	V_{OL_dig}	OUTPUT_SIGN_GLO, OUTPUT_MAGN_GLO – For channel 1; OUTPUT_SIGN_GPS, OUTPUT_MAGN_GPS For channel 2	-	-	100	mV
Input logic-level high	V_{IH}	For digital inputs	$0.7V_{cc}$	-	3.6	V
Input logic-level low	V_{IL}		-0.25	-	0.3	V

8 DELIVERABLES

Depending on license type IP may include:

- Schematic or NetList
- Abstract view (.lef and .lib files)
- Layout (optional)
- Verilog behavior model
- Extracted view (optional)
- GDSII
- DRC, LVS, antenna report
- Test bench with saved configurations (optional)
- Documentation