

---

## Rail to Rail LVDS receiver 2 Gbps

---

### SPECIFICATION

#### 1 FEATURES

- TSMC CMOS 65 nm
- 1.2 V CMOS input and output logic signals
- 2 Gbps (DDR MODE) switching rates
- Conforms to TIA and IEEE standards without hysteresis
- Rail to rail input range
- Optimized for pad-limited layout design
- Portable to other technologies (upon request)

#### 2 APPLICATION

- Point-to-point data receiver
- Multidrop buses
- Clock distribution
- Backplane receiver
- Backplane data receiver
- Cable data receiver

#### 3 OVERVIEW

LVDS\_RX is LVDS receiver with rail to rail input range. EN\_T enables 100 Ohm internal resistor. The CAL\_T<1:0> adjusts 100 Ohm internal resistor, the design target is to compensate the resistance deviation. The VREF12 is input 1.2 V voltage reference. Pin IREF\_RX to get current 20 uA reference from receiver bias. INP and INN are complementary input to connect to the bonding pads. This LVDS receiver does not employ hysteresis, and therefore does not comply with the hysteresis requirement of the TIA and IEEE standards for LVDS differential signaling at the specified rates.

The block is designed on TSMC CMOS 65 nm technology.

## 4 STRUCTURE

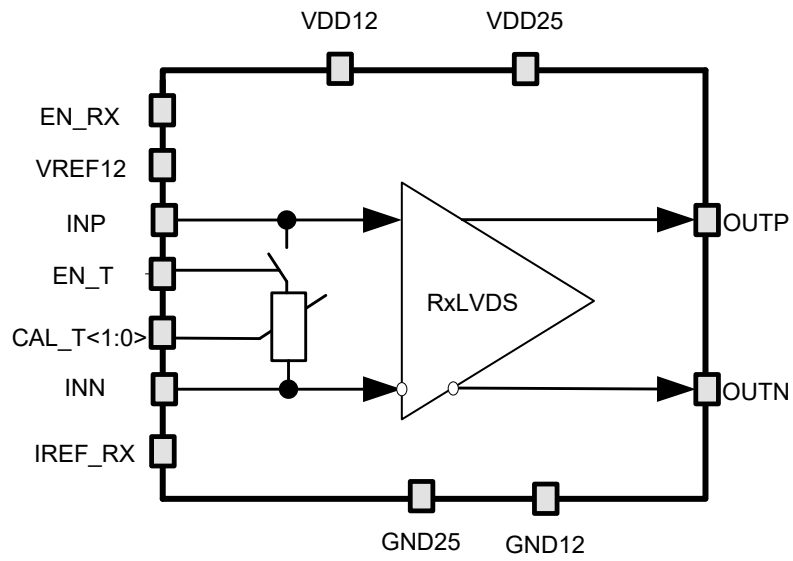

Figure 1: LVDS structure

## 5 PIN DESCRIPTION

Name	Direction	Description
IREF_RX	I	Reference current 20 uA
VREF12	I	Reference voltage 1.2 V
EN_T	I	On-chip resistor enable
CAL_T<1:0>	I	On-chip resistor value adjust
EN_RX	I	LVDS receiver enable
INP	I	Input differential LVDS signal
INN		
OUTP	O	Output differential 1.2 V CMOS signal
OUTN		
VDD12	IO	Supply voltage 1.2 V
VDD25	IO	Supply voltage 2.5 V
GND25	IO	Analog ground
GND12	IO	Digital ground

Table 1: LVDS receiver truth table

Mode	Input			Output	
	EN_RX	PAD_INP	PAD_INN	OUTp	OUTn
Receive	1	1	0	1	0
		0	1	0	1
Power down	0	X	X	1	0

Table 2: Input 100 Ohm resistor compensation

Input		On-Chip 100Ohm Resistor compensation
RES_CAL<1>	RES_CAL<0>	
0	0	-10 %
0	1	0 %
1	0	0 %
1	1	+10 %

## 6 LAYOUT DESCRIPTION

Rail to Rail LVDS dimensions are given in the table 3.

Table 3: Block dimension

Dimension	Value	Unit
Height	210	um
Width	235	um

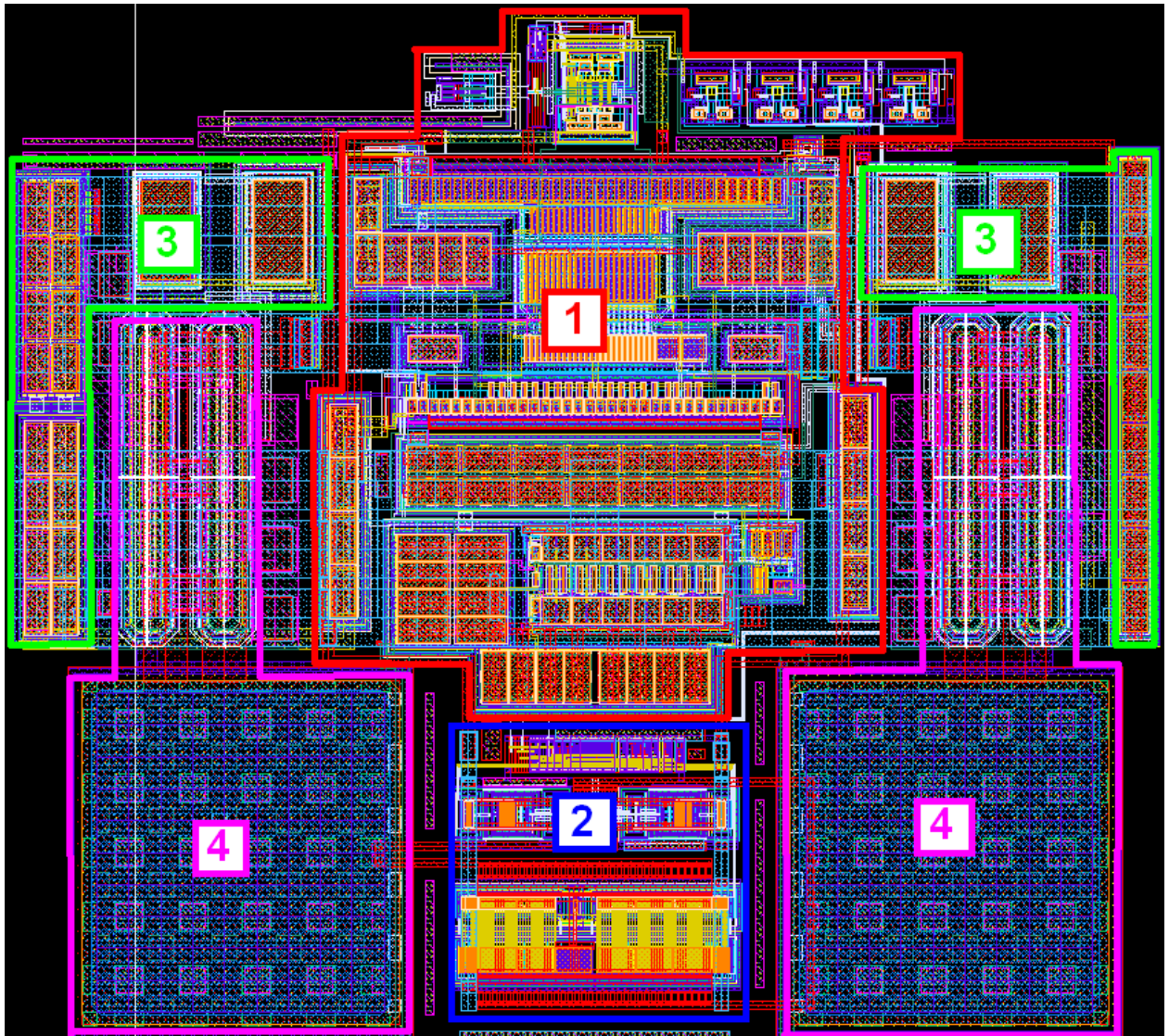

Figure 2: Rail to rail LVDS Receiver with pads layout

1. Rail to rail LVDS receiver
2. Input 100 Ohm resistor
3. Capacitance
4. Pads

## 7 OPERATING CHARACTERISTICS

### 7.1 TECHNICAL CHARACTERISTICS

Technology \_\_\_\_\_ TSMC CMOS 65 nm  
 Status \_\_\_\_\_ silicon proven  
 Area \_\_\_\_\_ 0.049 mm<sup>2</sup>

### 7.2 ELECTRICAL CHARACTERISTICS

The values of electrical characteristics are special for  $V_{dd25} = 2.25 \div 2.75$  V,  $V_{dd12} = 1.08 \div 1.32$  V,  $T_j = -40 \div +85$  °C. Typical value are at  $V_{dd25} = 2.5$  V,  $V_{dd12} = 1.2$  V,  $T_j = +27$  °C,  $V_{id} = |V_{INP} - V_{INN}| = 100$  mV unless otherwise specified.

Parameter	Symbol	Condition	Value			Unit
			min	typ.	max	
Supply analog voltage	$V_{dd25}$	-	2.25	2.5	2.75	V
Supply digital voltage	$V_{dd12}$	-	1.08	1.2	1.32	V
Operating temperature range	$T_j$	-	-40	27	+85	°C
Input current range	$I_{in}$	EN_T= "1"	-	-	10	mA
Input voltage range	$V_{in}$	-	0	1.2	2.4	V
Input differential threshold	$V_{th}$	-	-	-	100	mV
Receiver differential input impedance	$R_{in}$	With calibration	90	100	110	$\Omega$
		Without calibration $T\_CAL<1:0> = "10"$ or $T\_CAL<1:0> = "01"$	83	100	120	
		Without calibration $T\_CAL<1:0> = "11"$	90	109	130	
DC power current from $V_{dd25}$	$I_{VDD25}$	-	1.9	2.06	2.3	mA
DC total power	$P_{total}$	-	4.3	5.1	6.3	mW
Stand-by current	$I_{st\_vdd25}$	-	12	21	98	nA
Stand-by current	$I_{st\_vdd12}$	-	1	1.7	257	nA
Output voltage range	$V_{out}$	-	0	-	1.2	V
Differential propagation delay, high to low	$t_{PHLDT}$	-	453	587	872	ps
Differential propagation delay, low to high	$t_{PLHDT}$	-	453	587	873	ps
Average current from $V_{dd25}$	$I_{VDD25}$	$F_{clk} = 1$ GHz	2.26	2.5	2.83	mA
Average current from $V_{dd12}$	$I_{VDD12}$		78	89	103	uA
Total average power	$W$		5.2	6.3	7.9	mW
Deterministic jitter, peak-to-peak	$t_{DJ}$	2 Gbps	-	8.8	31	ps
		1.8 Gbps	-	6.8	13.3	ps
		1.6 Gbps	-	6.1	7.6	ps
Random jitter, rms	$t_{RJ}$	$V_{id} = 100$ mV, $F_{clk} = 1$ GHz	312	413	973	fs
Random jitter, max (p-p)	$t_{DJM}$		4.4	5.8	13.6	ps
Random jitter, rms	$t_{RJ}$	$V_{id} = 250$ mV, $F_{clk} = 1$ GHz	154	194	388	fs
Random jitter, max (p-p)	$t_{DJM}$		2.1	2.7	5.4	ps
Input voltage high level	$V_{IH}$	For digital inputs	$0.8 V_{dd12}$	-	$V_{dd12}$	V
Input voltage low level	$V_{IL}$		0	-	$0.2 V_{dd12}$	V

## **8 DELIVERABLES**

Depending on license type IP may include:

- Schematic or NetList
- Layout or blackbox
- Verilog, lef and lib files
- Extracted view (optional)
- GDSII
- DRC, LVS, antenna report
- Test bench with saved configurations (optional)
- Documentation