

## Phase frequency detector and charge pump

### SPECIFICATION

#### 1 FEATURES

- iHP SiGe BiCMOS 250 nm
- CMOS input signals
- Low disbalance of output current
- Portable to other technologies (upon request)

#### 2 APPLICATION

- Phase-locked loop synthesizer

#### 3 OVERVIEW

Phase-frequency detector (PFD) forms control signal for VCO tuning. PFD compares phases of divided VCO signal and divided reference oscillator signal and detects phase difference. Charge pump generates pulses to change VCO control voltage.

The block is fabricated on iHP SiGe BiCMOS 250 nm technology.

#### 4 STRUCTURE

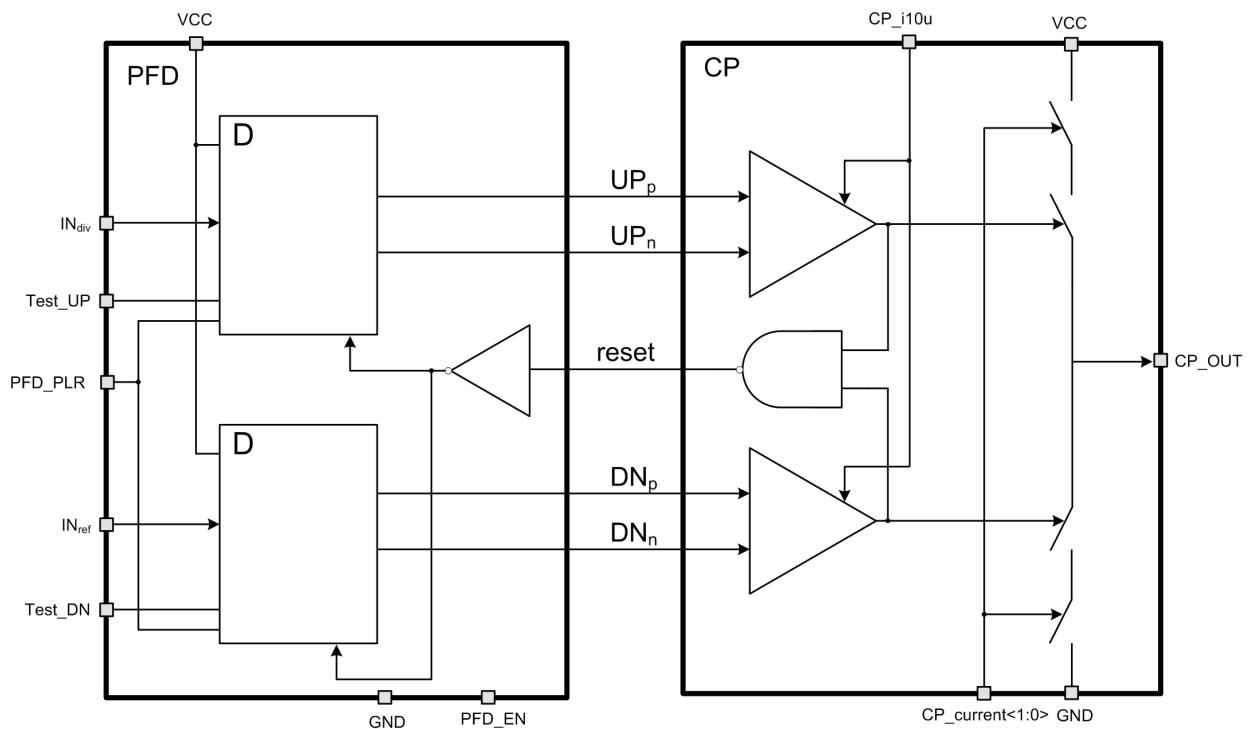

Figure 1: Phase frequency detector and charge pump structure

## 5 PIN DESCRIPTION

Name	Direction	Description
CP_i10u	IO	CP reference current 10 uA
IN <sub>div</sub>	I	PLL VCO divided signal input
IN <sub>ref</sub>	I	PLL reference oscillator divided signal input
PFD_PLR	I	PFD polarity
PFD_EN	I	PFD and CP enable/disable
Test_UP	I	Enable/disable of PFD up static current test mode
Test_DN	I	Enable/disable of PFD down static current test mode
CP_OUT	IO	CP output
CP_current<1:0>	I	Output current adjustment
GND	IO	Ground
VCC	IO	Supply voltage

## 6 LAYOUT DESCRIPTION

Frequency-phase detector and charge pump dimensions are given in the table 1.

**Table 1:** Blocks dimensions.

Dimension	Value	Unit
Height	205	um
Width	180	um

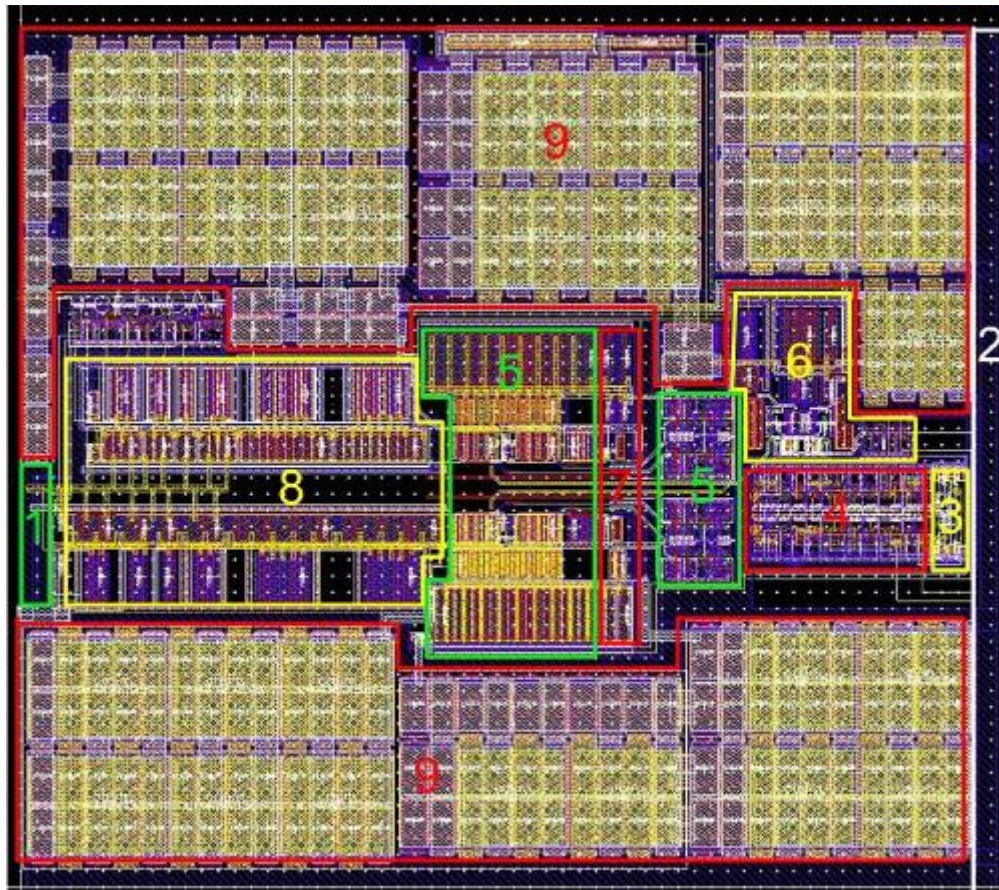

**Figure 2:** PFD and CP layout view

1. Ground bus
2. Supply voltage bus
3. Polar switch
4. PFD
5. Charge pump input buffer
6. PFD reset circuit
7. Charge pump reference current source
8. Charge pump output stage
9. Filter capacitors

## 7 OPERATING CHARACTERISTICS

### 7.1 TECHNICAL CHARACTERISTICS

Technology \_\_\_\_\_ iHP SiGe BiCMOS 250 nm  
 Status \_\_\_\_\_ silicon proven  
 Area \_\_\_\_\_ 0.04 mm<sup>2</sup>

### 7.2 ELECTRICAL CHARACTERISTICS

The values of electrical characteristics are specified for  $V_{cc} = 2.65 \div 2.75$  V and  $T_a = -60 \div +125$  °C. Typical values are at  $V_{cc} = 3.15$  V,  $T_a = +27$  °C, unless otherwise specified.

Parameter	Symbol	Condition	Value			Unit
			min	typ	max	
Supply voltage	$V_{cc}$	-	2.6	2.7	2.75	V
Operating temperature range	$T_a$	-	-60	+27	+125	°C
Reference frequency	$F_{ref}$	-	0.32	2.0	10	MHz
Peak-to-peak input voltage	$A_{in\ p-p}$	For inputs $IN_{div}$ , $IN_{ref}$	$V_{cc}-0.3$	$V_{cc}$	$V_{cc}+0.05$	V
Charge pump output current	$I_{out}$	Preset 1	40	41	42	uA
		Preset 2	60.5	61.5	63	
		Preset 3	91	91.5	94	
		Preset 4	136	137	140.5	
PFD reset time	$t_{rst}$	-	2.5	3.0	3.7	ns
Supply current	$I_{cc}$	Preset 4	0.61	0.62	0.65	mA
Stand-by current	$I_{stb}$	Preset 4	0.3	0.05	0.25	nA
Input logic-level high	$V_{IH}$	For digital inputs	$0.7V_{cc}$	-	$V_{cc}+0.25$	V
Input logic-level low	$V_{IL}$		-0.25	-	0.3	V

## 8 DELIVERABLES

IP contents:

- Schematic or NetList
- Layout or blackbox
- Extracted view (optional)
- GDSII
- DRC, LVS, antenna report
- Test bench with saved configurations (optional)
- Documentation