



**NTL ADP BOARD**  
**INTERFACE ADAPTER FOR**  
**NTL10X OEM MODULES FAMILY**

Manual



2020



## CONTENTS

1 STRUCTURE AND DESCRIPTION .....	3
2 CONNECTOR PINOUTS .....	5
3 SPECIFICATIONS .....	6
CONTACTS .....	7

## 1 STRUCTURE AND DESCRIPTION

NTL Adp Board (interface adapter) is designed for user-friendly access to available interfaces of NTL10X navigation modules. It can be used at the design stage of applications to test performance of the board within that applications as well.

The top of the NTL Adp Board is presented in figure 1.1.

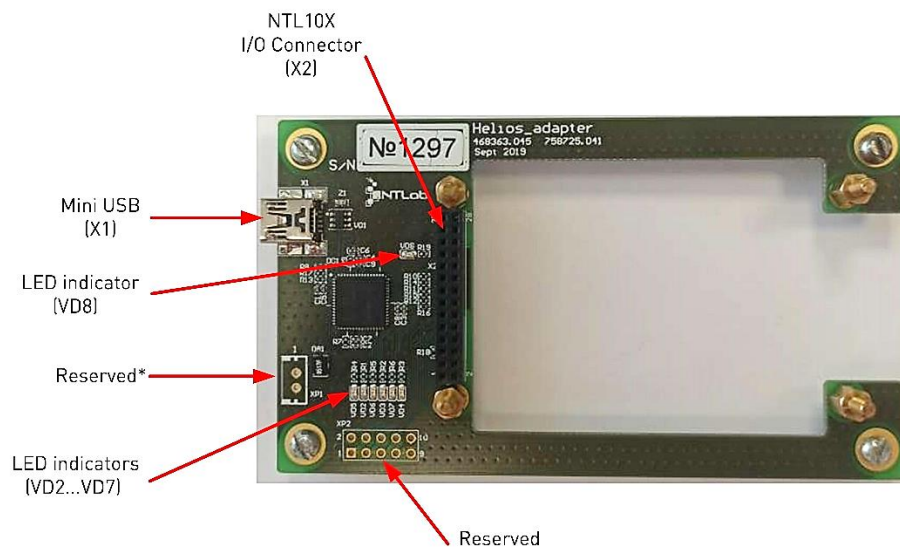

Figure 1.1 – NTL Adp Board Layout

### **Connectors:**

- a standard mini USB connector (X1 );
- PBD2-28 I/O connector type (X2): with backward compatibility for current industry standards.

### **LED indicators:**

- VD2: green LED is the UART3 TX line indicator;
- VD3: green LED is the UART2 TX line indicator;
- VD4: green LED is the UART1 TX line indicator;
- VD5: green LED is the UART3 RX line indicator;
- VD6: green LED is the UART2 RX line indicator;
- VD7: green LED is the UART1 RX line indicator;
- VD8: green LED is the «Position Valid» (PV) indicator.

The hardware block diagram of the NTL Adp Board is presented in figure 1.2.

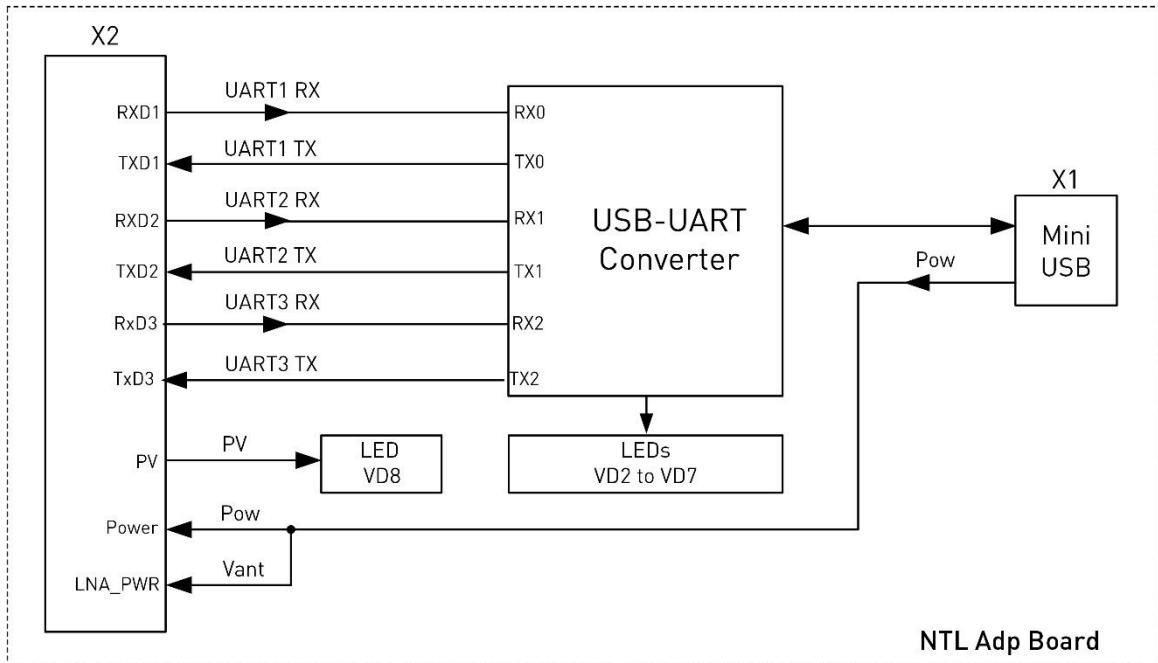

Figure 1.2 – NTL Adp Board block diagram

**I/O Interfaces:**

- 3xCMOS\_2.5 serial ports (UART type);
- 3xVirtual COM ports on mini USB.

UART interfaces are connected to mini USB connector as the virtual COM ports via USB-UART converter (CP2108-B02-GM).

**Power supply:**

The board power supply and antenna power supply is provided by the host PC through the USB cable:

- DC power supply 5V.

## 2 CONNECTOR PINOUTS

The description and assignment of the X2 PBD2-28 pinouts are presented in table 2.1.

Table 2.1 – X2 pinouts

Pin No	Name	I/O	Description
1	USB_ID	-	not connected
2	USB_VBUS		
3	BOOT		
4	TPO-MID		
5	LNA_PWR	Power	Antenna power supply voltage
6	Power		Board power supply voltage
7	USB_D-	-	not connected
8	USB_D+		
9	GRESET	Output	Reset control (reserved)
10	MF01 <sup>1</sup>	I/O	MCU STM32H7 GPIO
11	MF02 <sup>1</sup>	I/O	MCU STM32H7 GPIO
12	TxD3	Output	UART3 TX line
13	EVENT <sup>1</sup>	Output	MCU STM32H7 (reserved)
14,17,20,22	GND	Power	Signal and Power Ground
15	RXD1	Input	UART1 RX line
16	TXD1	Output	UART1 TX line
18	RXD2	Input	UART2 RX line
19	RXD2	Output	UART2 TX line
21	PV	Input	«Position Valid» indicator
23	PPS	Input	PPS time mark
24	RxD3	Input	UART3 RX line
25	TPO+	-	not connected
26	TPI+		
27	TPO-		
28	TPI-		

<sup>1</sup> It is implemented in hardware for compatibility with Trimble and Novatel receivers, having the same form factor

### 3 SPECIFICATIONS

The NTL Adp Board has the following main characteristics:

- Interfaces: USB, UART;
- Data rate:
  - USB interface: mini USB up to 12 Mbps (USB Full Speed);
  - UART interface: up to 2 Mbps;
- Supply voltage:
  - USB voltage 5V;
- Power consumption: <200 mW (without OEM module);
- Operating temperature: -40° to +85°C.

## CONTACTS

For complete contact information visit us at [www.ntlab.com](http://www.ntlab.com)

### Head Office

4th floor, 41 Surganova str., 220013 Minsk, Republic of Belarus

Tel.: +375 17 290 09 99

Fax: +375 17 290 98 98

e-mail: [ntlab@ntlab.com](mailto:ntlab@ntlab.com), [sales@ntlab.com](mailto:sales@ntlab.com)

### EU Branch Office

NTLAB, UAB

Švenčionių g. 112, Nemenčinė, LT-15168 Vilniaus r., Lithuania

Tel.: +370 6 169 5418

e-mail: [sales@ntlab.lt](mailto:sales@ntlab.lt)

