

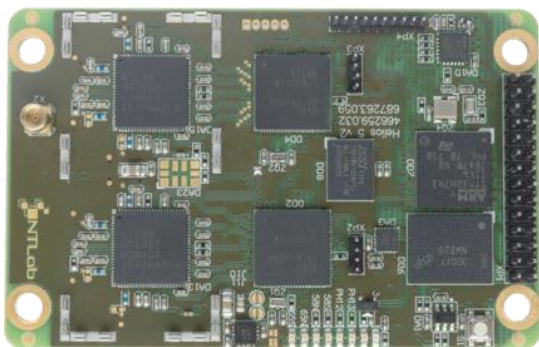

NTL106

OEM GNSS RECEIVER MODULE

Datasheet



CONTENTS

1 NTL106 TECHNICAL DOCUMENTS	2
2 NTL106 FUNCTIONAL DIAGRAM AND OPERATIONAL ASPECTS.....	3
3 MODULE STRUCTURE, TOP VIEW AND INDICATION	6
4 TECHNICAL PARAMETERS	9
5 COMMUNICATION PORTS AND PIN DEFINITION	10
6 BOARD LAYOUT AND DIMENSIONS.....	12
CONTACTS.....	13

1 NTL106 TECHNICAL DOCUMENTS

The complete information about **NTL106** OEM GNSS receiver module includes:

- **Actual datasheet.** Contains information about the **NTL106** structure, its basic features, technical specification, pin definitions, etc. It gives some utilization aspects specific for particular receiver structure.
- **GNSS-PPU-SETUP-GUIDE-AA-BB-CC.pdf.** It describes the concept of PPU (Primary Processing Unit), the basic object of the NTLab GNSS receivers. Then **NTL106** structure will be described in terms of PPU. It contains detailed information about operational aspects of GNSS receivers which have AA-BB version of embedded firmware (CC – revision of the document). Refer to this document to get information about available operational modes, control parameters, some internal logic aspects and interface commands which are used to control the receiver performance.
- **GNSS-DCP-BUILD-AA-BB-CC.pdf.** It contains information about Data Communication Protocols from the firmware version AA-BB. It describes how to parse data coming from **NTL106**, how to construct control commands and how to use the receiver in the most optimal way.
- **NTL-BROWSER-GIUDE-CC.pdf.** It contains a quick guide for NTL Browser software tool designed by NTLab. It is a Windows 7/10 utility. It is used to visualize data coming from the receiver, to control receiver configuration, to update firmware. It is useful to a “fast start” with GNSS receiver.
- **NTL10X-ADP BOARD-MANUAL-CC.pdf.** It contains information about interface and power adapter which can be used to connect the **NTL106** to peripheral devices (PC), as well as to verify various module operation mode.

Documents can be revised by NTLab at any time. Visit www.ntlab.it for the latest version of the documents.

2 NTL106 FUNCTIONAL DIAGRAM AND OPERATIONAL ASPECTS

The NTL106 is a single-antenna multi-band OEM GNSS receiver module that can be used for the following purposes:

- as a source of navigational data (Position, Velocity, Time) in autonomous mode (standalone mode, GPS+SBAS), 1Hz;
- as a source of navigational data (Position, Velocity, Time) in RTK mode (a source of Base Station measurements is required), 10Hz;
- as a source of raw ranging measurements (include pseudoranges, measured by code and carrier phase), 20Hz;

NTL106 consists of three functional blocks:

- PPU1;
- PPU2;
- RTK-Engine.

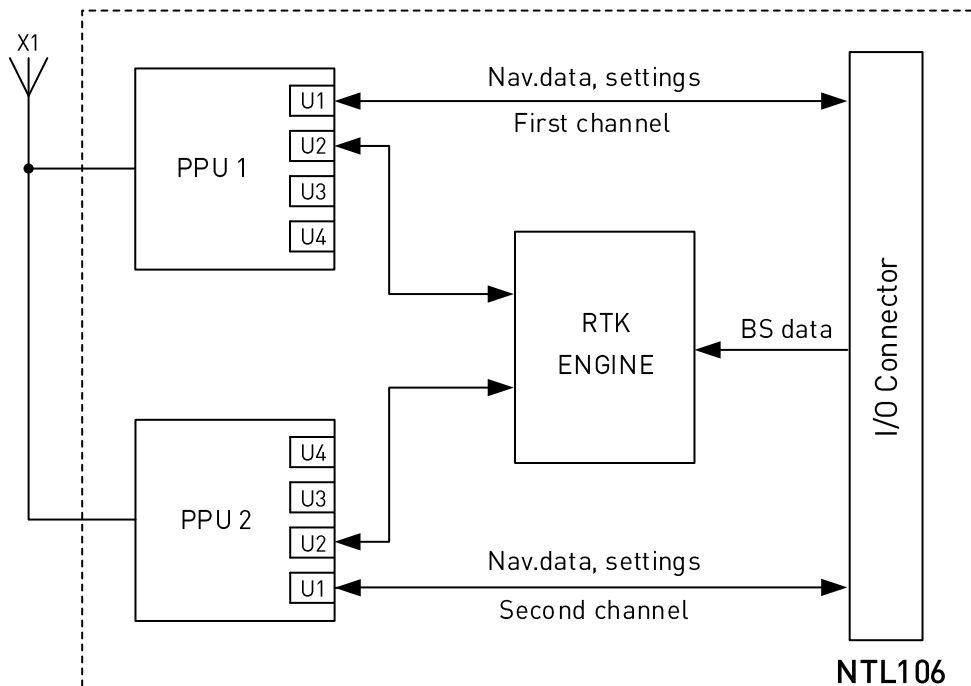

Figure 2.1 – NTL106 functional diagram

PPU – Primary Processing Unit – is a basic functional block of OEM GNSS module. The definition of PPU is given in «GNSS-PPU-SETUP-GUIDE-AA-BB-CC.pdf» document. It is a simple GNSS module with an autonomous positioning mode.

NTL106 contains two PPU's, which have different system settings. By default, the PPU1 and the PPU2 is configured as follows:

- PPU1 tracks GPS, GLONASS and NavIC signals (including SBAS);
- PPU2 tracks Galileo and BeiDou signals (including SBAS).

It allows to receive and to process the maximum number of various navigation systems satellites. As result, the maximum number of raw ranging measurements can be formed. It is enough to combine raw ranging measurements from two independent channels (first channel and second channel) by the utility which is designed by the NTLab company, for the next post-processing of the data. The utility combines two RTCM MSM data streams into one stream. Data sources can be files, COM ports, or TCP/IP ports. The receiver of data can also be a file, COM port or TCP/IP port.

There are more sophisticated positioning modes available in combination with PPU1, PPU2 and RTK Engine.

Purpose of functional blocks:

- *PPU1* provides next functionality:

- computation of position and velocity in standalone and SBAS modes;
- computation of precise time and generation of Pulse Per Second (PPS) strobes;
- generation of raw ranging measurements, based on code and carrier phase measurements.

- *RTK-Engine* is a kind of coprocessor. It provides additional computations for differential positioning (RTK-FIX, RTK-FLOAT, RTK-CDDIFF) in static and moving-base modes. It allows computation of the differential vector with the rate up to 10Hz. Differential vector is a vector which connects the phase centers of two antennas (NTL106 antenna and Base Station (BS) antenna). Base station is reference receiver whose precise coordinates are known. The base station data must be provided to implement this mode. High accuracy position of NTL106 antenna is available when this vector is determined.

- *PPU2* provides next functionality:

- computation of position and velocity in standalone and SBAS modes;
- computation of precise time and generation of Pulse Per Second strobes;
- generation of raw ranging measurements, based on code and carrier phase measurements.

Its purpose in NTL106 architecture is to provide RTK-Engine additional raw ranging measurements. It is not recommended to configure PPU2 for RTK mode, although it is a full-function PPU with the same basic features as PPU1.

Refer to «GNSS-DCP-BUILD-AA-BB-CC.pdf» to get detailed information about its modes, control parameters, etc.

NOTES:

- *Commutation*

Each PPU has four physical UART modules. Only two of them are active – UART1 and UART2.

In PPU1 and PPU2, UART2 is used for internal purpose – interaction with RTK-Engine. It is not available for NTL Binary or raw ranging measurements transmission while RTK function is on.

In PPU1 and PPU2, UART1 is brought out to the I/O connector pins. It is the only physical channel to communicate with PPU.

One more UART channel available on the I/O connector is used to receive base station data and connected directly to RTK-Engine module. Use `BMT_CONFIG.UART4_CTRL` command to setup bitrate of that port.

One more option is available for **NTL106**, besides basic configuration. It is OPEN-PLATFORM.

OPEN-PLATFORM is a configuration for customers who are interested in implementation of own post processing algorithms. Such configuration is provided without embedded firmware RTK functionality. MCU is available for programming and debugging. Both PPUs can be used as sources of raw ranging measurements and other information which is required for implementation of positioning algorithms. Measurements are based at all available civil GNSS signals at the moment. If you are interested in it, please, refer to NTLab company.

3 MODULE STRUCTURE, TOP VIEW AND INDICATION

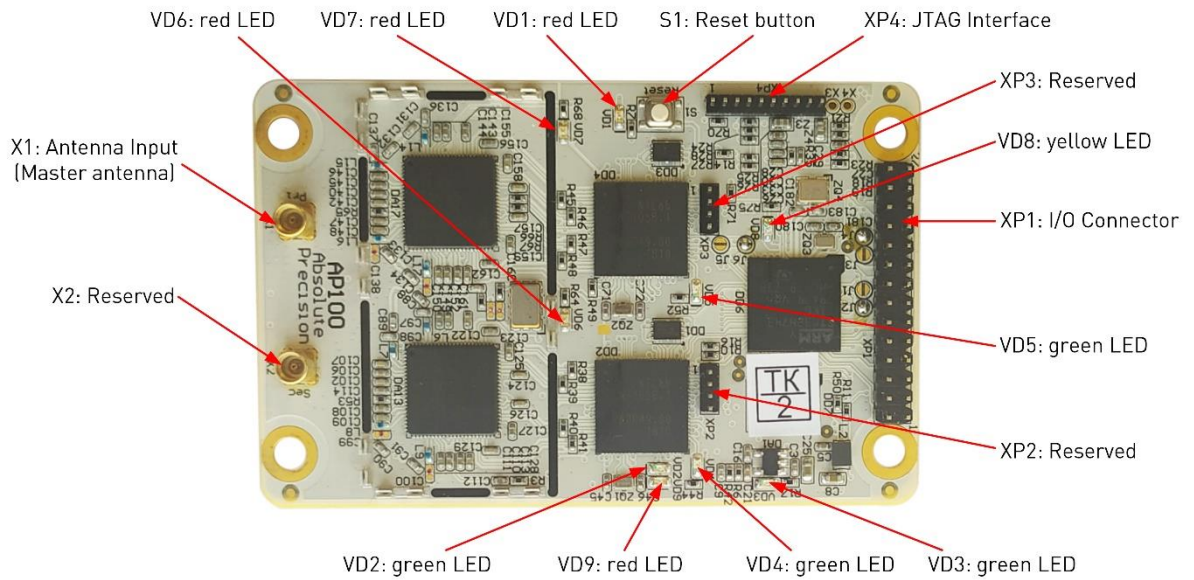

Figure 3.1 – NTL106 top view

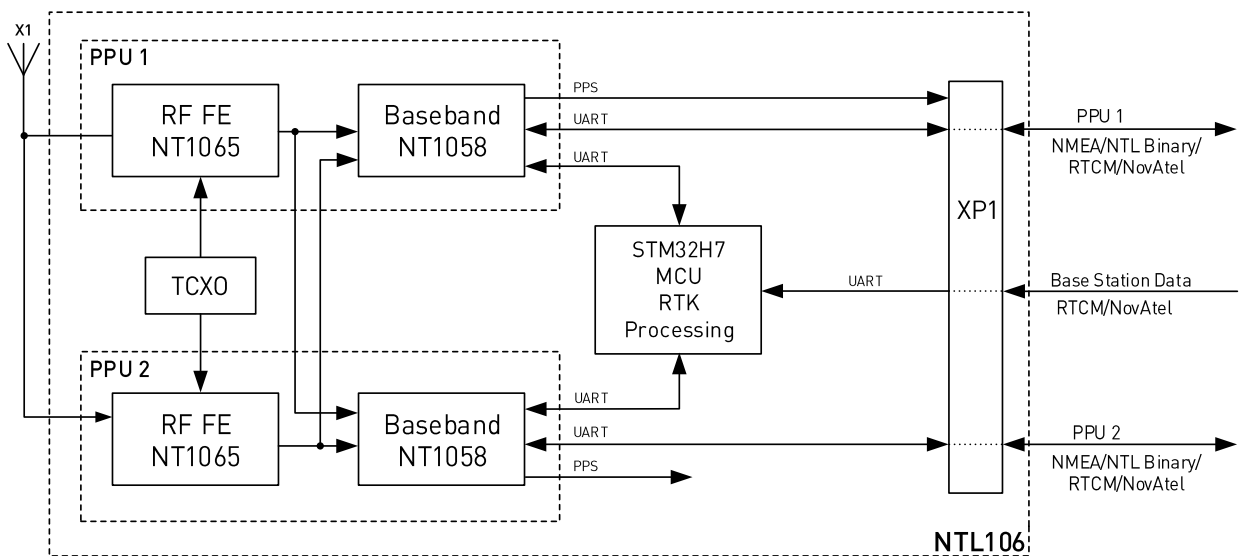

Figure 3.2 – NTL106 structural diagram

Both PPU's have equal hardware platform. They are implemented on chips set which are designed by NTLab company:

- NT1065 is a 4-channel L1, L2, L5 band Radio-Frequency Front-End (RF FE) integrated circuit for GNSS signals reception: for amplification, filtering and down converting of the received signals to a fixed intermediate frequency (IF);
- NT1058 is microcontroller which includes digital baseband processor and 64 dual channels (128 independent) hardware correlator for signals tracking and primary processing of digital signals.

RTK-Engine is based on STM32H7 MCU having 400 MHz system clock and double word FPU coprocessor.

Connectors:

- X1 are the MMCX type connector for external active antenna¹ commutation. Central pin provides DC voltage for antenna power supply. DC voltage is wired from Pin 5 of I/O Connector XP1. It means that a **NTL106** host-device must provide DC voltage in accordance with active antenna requirements.
- XP1 is a PLD2-28 connector. Form factor of the board and XP1 pin-out is compatible with popular GNSS receiver families (Novatel 6xx, Trimble and others). Refer to Chapter 5 for XP1 pinout, refer to Chapter 6 for PCB dimensions.
- XP4 is a PLS-10 connector for STM MCU debugging and programming with JTAG.

LEDs:

- Red LED VD1 is indicator of the Reset control.
- Green LED VD2 is indicator of the antenna power supply (Green Solid).
- Green LED VD3 is indicator of the 3.3V DC voltage for the module power supply (Green Solid).
- Green LEDs VD4 and VD5 are the indicators of NT1058 normal performance in the PPU1 and the PPU2. It should blink once per second during normal operation (Green Blinking).
- Red LEDs VD6 and VD7 are the indicators of the RF FE normal operation. It is OFF during normal operation (No Light). If those LEDs are ON, please, check active antenna circuitry. This may indicate not appropriate level of amplification in active antenna: too low or too high.
- Yellow LED VD8 is indicator of the RTK-Engine normal operation (Yellow Solid).

¹ GNSS External Active Antenna Requirements:

- Antenna voltage supply 5V;
- Maximum current 100mA;
- LNA Gain Range (minus signal loss) 20...35dB.

- Red LED VD9 is indicator of the erroneous situation (backward current) in antenna power circuit. Should be OFF during normal operation (No Light).

So, nine user LED indicators (VD1...VD9) allow you to monitor the status of some nodes of the board: the board power status, the current operation status, malfunction. Green LEDs indicate correct operation. Red LEDs indicate a fault.

4 TECHNICAL PARAMETERS

Table 4.1 – Technical parameters

Supported GNSS signals												
PPU	GPS			GLO		GAL			BDO		IRN	
	L1	L2	L5	L1	L2	E1	E5b	E5a	B1	B2	L5	S
PPU1	+	+/- or -/+		+	+	+	+/- or -/+		+	+	+	-
PPU2	+	+/- or -/+		+	+	+	+/- or -/+		+	+	+	-
Measurement Precision												
		Precision, RMS			Units			Notes				
C/A pseudoranges		20			cm			Smoothed pseudoranges				
L1, L2 carrier phase		0.8			mm							
Positioning modes and accuracy												
		Accuracy, RMS			Units		Notes					
		Plane	Vertical									
Autonomous	Standalone	1.2	1.5		m		Depends on atmospheric conditions, satellite visibility and geometry, multipath conditions, GNSS antenna					
	DGPS	0.4	0.6		m		GPS+SBAS					
Differential	CDDIFF	1.0	1.5		m		Depends on the baseline length.					
	FLOAT	0.5	0.75		m							
	FIX	5+0.5ppm	8+1.0ppm		mm							
Data update rates												
Position, velocity, time	Standalone mode			1		Hz		no options				
	Differential mode			10		Hz		1,5 Hz available				
Raw data					20		Hz		1,5,10 Hz available			
Electro-mechanical characteristics												
Operating temperature, °C		-55 to +85			Storage temperature, °C			-40 to +80				
Supply voltage, V		3.3 to 5.3			Power consumption, W			<1.8				
Dimensions (L x W x H), mm		71 x 46 x 10			All specifications are at an ambient temperature of 25 °C. Extreme operating temperatures can significantly impact specification values.							
Weight, g		< 45										

5 COMMUNICATION PORTS AND PIN DEFINITION

Table 5.1 – I/O connector XP1 pin definitions

Pin No	Name	I/O	Type	Description
1	USB_ID	Input	CMOS_3.3	STM32H7 MCU USB FS ²
2	USB_VBUS	Input		STM32H7 MCU USB FS ²
3	BOOT	Input		STM32H7 MCU boot mode selection
4	TPO-MID	Output		STM32H7 MCU ETHERNET ²
5	LNA_PWR	Power	Analog	Antenna power supply
6	Power	Power	Analog	NTL106 power supply voltage
7	USB_D-	I/O	CMOS_3.3	STM32H7 MCU USB FS ²
8	USB_D+	I/O		STM32H7 MCU USB FS ²
9	GRESET	Input	CMOS_3.3	Reset control (active-low)
10	MF01 ¹	I/O	CMOS_3.3	STM32H7 MCU GPIO
11	MF02 ¹	I/O		STM32H7 MCU GPIO
12	RxD3/CANRx ³	Input		UART3 Rx line (optionally Can Rx line)
13	EVENT ¹	Input		STM32H7 MCU
14,17,20,22	GND	Power	Analog	Signal and Power Ground
15	TXD1	Output	CMOS_2.5	PPU2 UART Tx line (UART1 Tx line)
16	RXD1	Input		PPU2 UART Rx line (UART1 Rx line)
18	TXD2	Output		PPU1 UART Tx line (UART2 Tx line)
19	RXD2	Input		PPU1 UART Rx line (UART2 Rx line)
21	PV	Output	CMOS_3.3	«Position Valid» indicator
23	PPS	Output	CMOS_2.5	PPS time mark (wired from PPU1)
24	TxD3/CANTx ³	Output	CMOS_3.3	UART3 Tx line (optionally Can Tx line)
25	TPO+	Output		STM32H7 MCU Ethernet ²
26	TPI+	Input		STM32H7 MCU Ethernet ²
27	TPO-	Output		STM32H7 MCU Ethernet ²
28	TPI-	Input		STM32H7 MCU Ethernet ²
Notes	<p>1- Signals are implemented in hardware for compatibility with Trimble and Novatel receivers which have the same form factor; not supported in actual firmware.</p> <p>2- It is hardware ready; basic firmware doesn't provide such options; may be developed on demand.</p> <p>3- UART3 TX/RX by default; CAN may be implemented on demand.</p>			

Table 5.2 – Basic configuration of NTL106 UART channels

Pin No	Name	Description
18	UART2 Tx	It provides access to PPU1 UART1 (UART1 in terms of PPU-SETUP-GUIDE). Available data transmission formats: <ul style="list-style-type: none"> • NMEA-0183 or NTL Binary for nav. data transmission and control; • RTCM3.3 (MSM+Legacy messages) or Novatel OEMv7 for raw ranging measurements transmission. Available baud rate diapason: 9600 to 460800. Default settings: 115200 Baud, 8 bits, no parity bit, 1 stop bit, NTL Binary.
19	UART2 Rx	
15	UART1 Tx	It provides access to PPU2 UART1 (UART1 in terms of PPU-SETUP-GUIDE). Available data transmission formats: <ul style="list-style-type: none"> • NMEA-0183 or NTL Binary for nav. data transmission and control; • RTCM3.3 (MSM+Legacy messages) or Novatel OEMv7 for raw ranging measurements transmission. Available baud rate diapason: 9600 to 460800. Default settings: 115200 Baud, 8 bits, no parity bit, 1 stop bit, NTL Binary.
16	UART1 Rx	
12	UART3 Rx	Base station data input. Available data formats: <ul style="list-style-type: none"> • RTCM3.1; • Novatel OEMv7 messages. Available baud rate diapason: 9600 to 460800. Default settings: 115200 Baud, 8 bits, no parity bit, 1 stop bit, RTCM3.1.
24	UART3 Tx	Not used
Refer to «GNSS-DCP-BUILD-AA-BB-CC.pdf» document to get more information about interface performance details.		

In OPEN-PLATFORM version definition of UART1, UART2 and UART3 data channels can be different. Up to three STM32H7 UART modules can be routed to XP1 connector as well as some GPIO signals and other peripherals. If you are interested in OPEN-PLATFORM version, please, refer directly to NTLab company for extended version of NTL106 datasheet.

6 BOARD LAYOUT AND DIMENSIONS

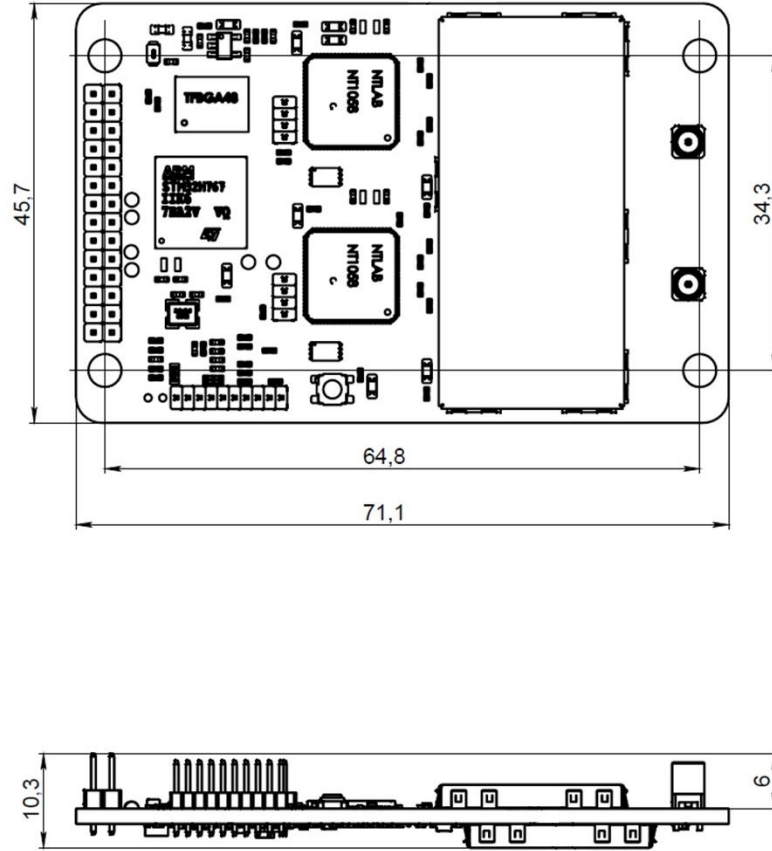

Figure 6.1 – NTL106 Board Layout and Dimensions

CONTACTS

For complete contact information visit us at www.ntlab.com

Head Office

4th floor, 41 Surganova str., 220013 Minsk, Republic of Belarus

Tel.: +375 17 290 09 99

Fax: +375 17 290 98 98

e-mail: ntlab@ntlab.com, sales@ntlab.com

EU Branch Office

NTLAB, UAB

Švenčionių g. 112, Nemenčinė, LT-15168 Vilniaus r., Lithuania

Tel.: +370 6 169 5418

e-mail: sales@ntlab.lt

