

1-TO-5 RF SPLITTER

1. OVERVIEW

SPL15 is 1-to-5 active splitter with L1, L2, L3, L5, S subbands RF preselection. It is intended to be used with navigational receivers if active antenna (cable losses included) will be plugged in. SPL15 provides less than 2dB of noise figure and more than 35dB out of band RF rejection. Every channel can be independently assembled to pass through one of available GNSS bands. SPL15 is optimal to be paired with NT1066 or NT1068 evaluation boards (<https://ntlab.lt/product-category/evaluation-kits/>).

2. KEY FEATURES

- 1 RF input with antenna supply capability (5V)
- 5 RF outputs
- 5V power supply connector

3. STRUCTURE

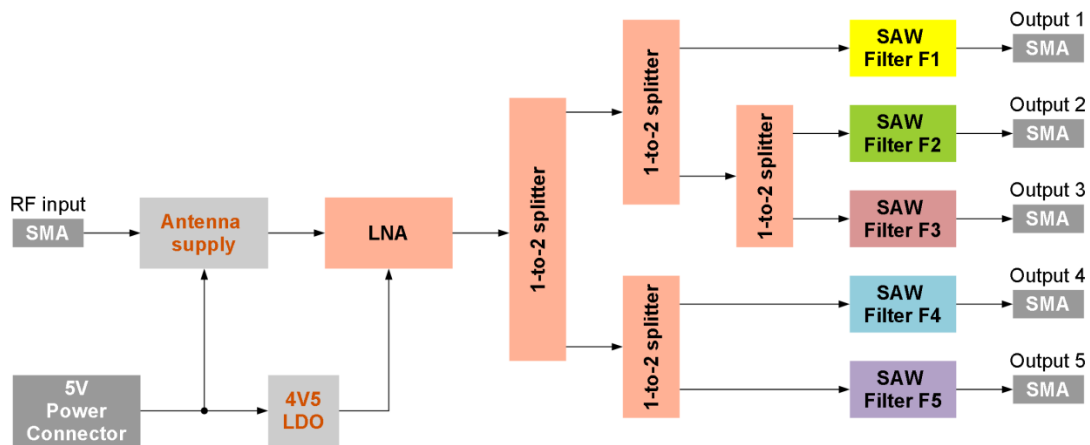

4. ORDERING INFORMATION

SPL15 -		X	X	X	X	X	S band	L1 GLO	L1 GPS	L1 QZSS	B1-C BeiDou	B1-A BeiDou	E1 Galileo	LEX QZSS	E6 Galileo	B3 BeiDou	L2 GLO	L2 GPS	L2 QZSS	L3 GLO	E5b Galileo	B2b BeiDou	E5a Galileo	B2a BeiDou	L5 GLO	L5 GPS	L5 QZSS	L5 NavIC
-	-	-	F4	-	1 - AV32 (2484-2500MHz)		•																					
					2 - TA0550A (1593-1609MHz)			•																				
					3 - TA0549A (1569-1582MHz)				•	•	•																	
					4 - B3423 / TA1785A (1560-1606MHz)			•	•	•	•	•	•															
F1	F2	F3	-	F5	5 - TA1104A (1145-1253MHz)											•	•	•	•	•	•	•	•	•	•	•	•	•
					6 - TFS1278A / TA1957A (1263-1293MHz)									•	•	•												
					7 - B3439 / TA0836A (1215-1254MHz)												•	•	•									
					8 - TA0582A (1180-1220MHz)															•	•	•						
					9 - B3452 / TA0675A (1166-1186MHz)																		•	•	•	•	•	•

Default assembly options are SPL15-45514 and SPL15-465X5. Availability of other assembly options should be requested.

Write **X** instead of filter number if no filter is needed in the channel, e.g. SPL15-455**X**4 if S band filter is not required, or SPL15-455**1**4 - if AV32 must be soldered in channel #4.

5. PACKAGE CONTENT

- 1-to-5 RF splitter
- Power supply cable
- 5 SMA-to-SMA RF cables



- Antenna supply indicator ●
- Antenna shortage indicator ●
- Splitter supply indicator ●

6. OPERATING CHARACTERISTICS

Parameter	Condition		Typical value	Unit
Supply voltage			5.0	V
Current consumption	At default assembly option		75	mA
Operating temperature			-40 ... +85	°C
Input frequency range	Channel #1	L1 band	1560–1606	MHz
		L2, L3, L5 bands	1145–1293	
	Channel #2	L1 band	1560–1606	
		L2, L3, L5 bands	1145–1293	
	Channel #3	L1 band	1560–1606	
		L2, L3, L5 bands	1145–1293	
	Channel #4	S band	2484–2500	
	Channel #5	L1 band	1560–1606	
		L2, L3, L5 bands	1145–1293	

7. APPLICATION EXAMPLES

7.1. SPL15-45514 & NT1066_EVK

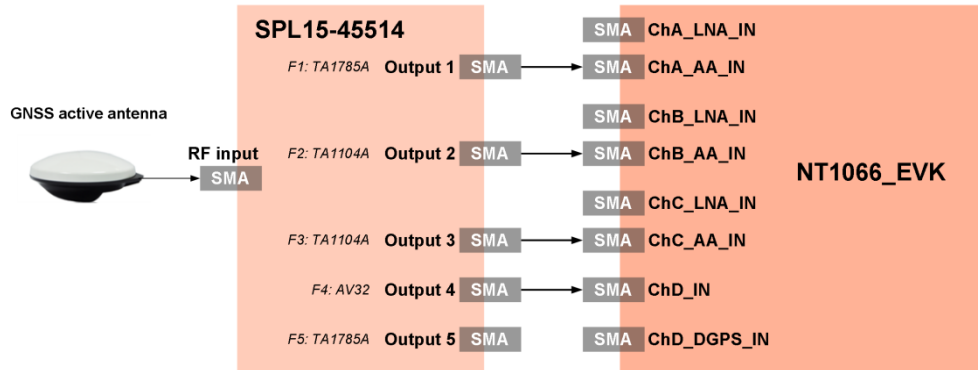

Splitter channels frequency response:

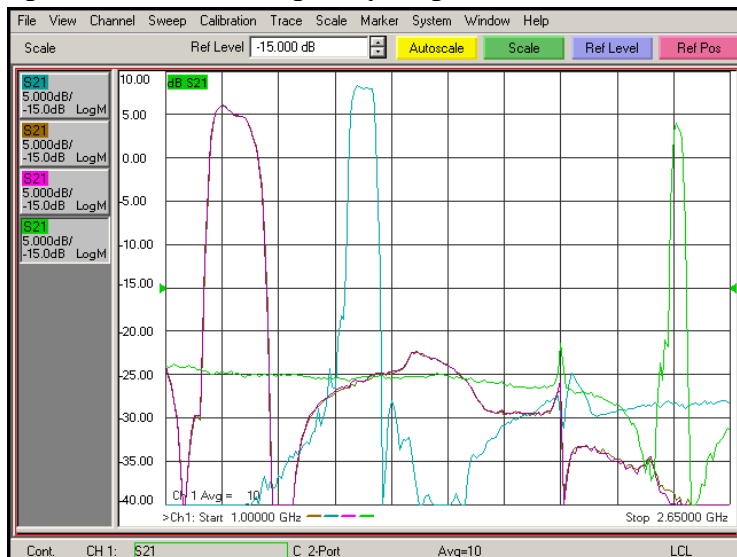

Splitter parameters:

Power gain, dB (typ)

Channel #1	8.0
Channel #2	5.0
Channel #3	5.0
Channel #4	4.0
Channel #5	8.0

Noise figure, dB (typ)

Channel #1	1.6
Channel #2	2.0
Channel #3	2.0
Channel #4	1.8
Channel #5	1.6

The following signals can be received with NT1066 IC:

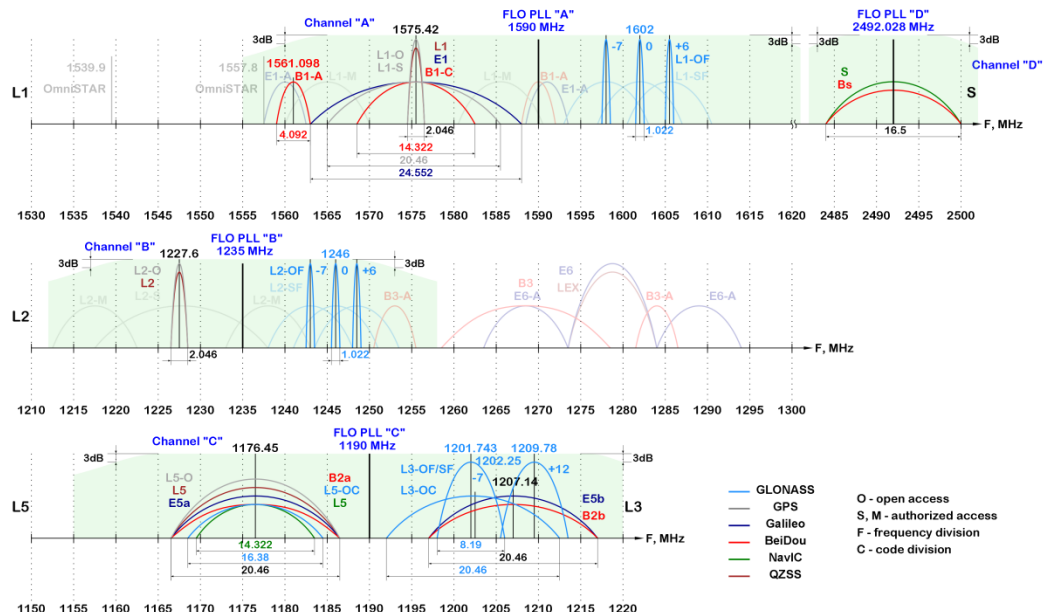

7.2. SPL15-465X5 & NT1066_EVK

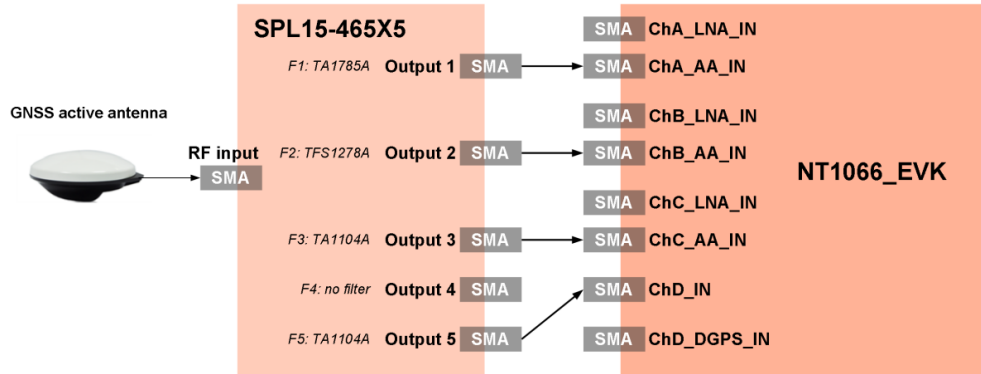

Splitter channels frequency response:

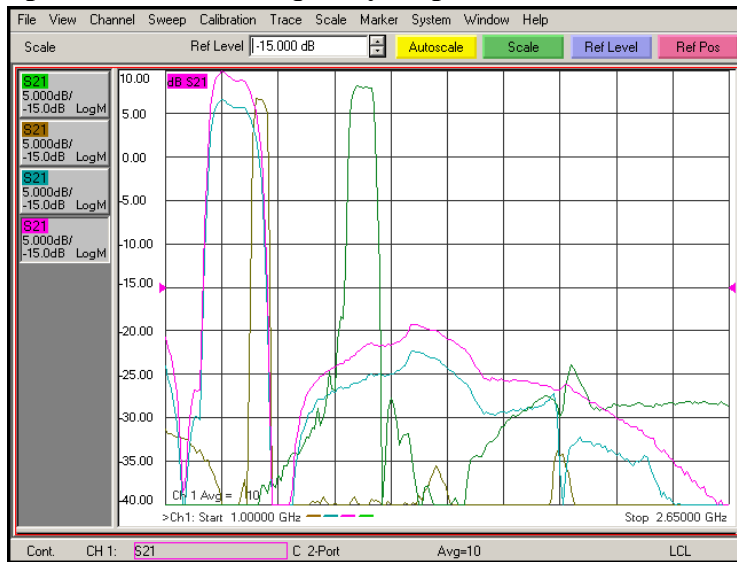

Splitter parameters:

Power gain, dB (typ)

Channel #1	8.0
Channel #2	6.5
Channel #3	5.0
Channel #4	6.0
Channel #5	9.0

Noise figure, dB (typ)

Channel #1	1.6
Channel #2	2.0
Channel #3	2.0
Channel #4	1.4
Channel #5	1.4

The following signals can be received with NT1066 IC:

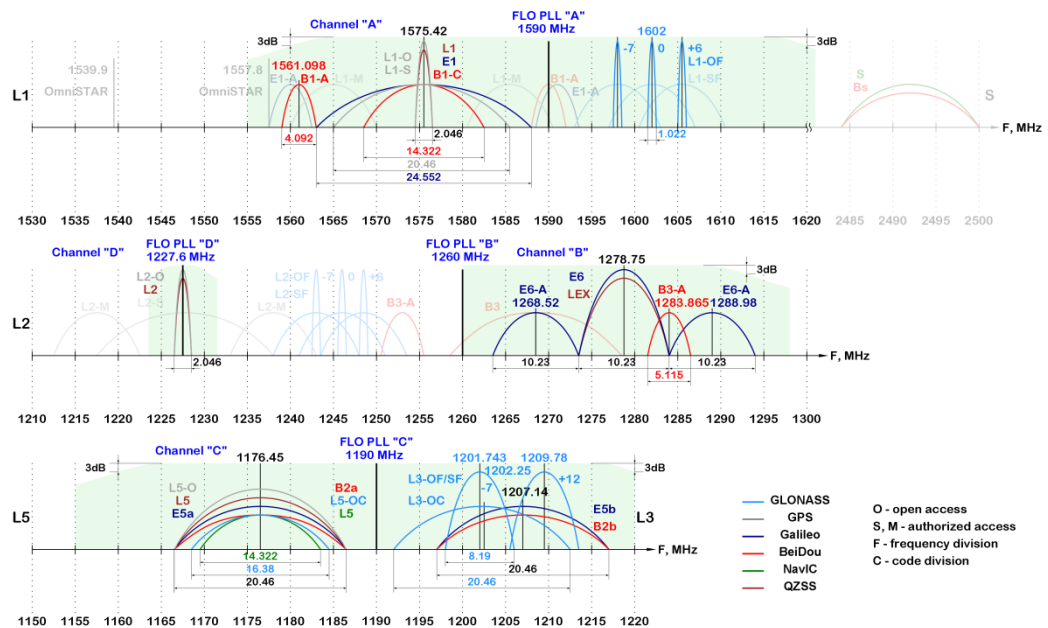

7.3. SPL15-45514 & NT1068_EVK

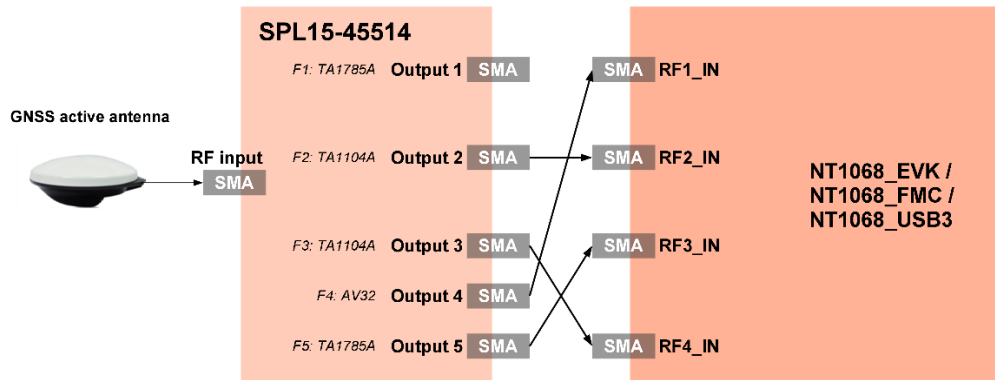

Splitter channels frequency response:

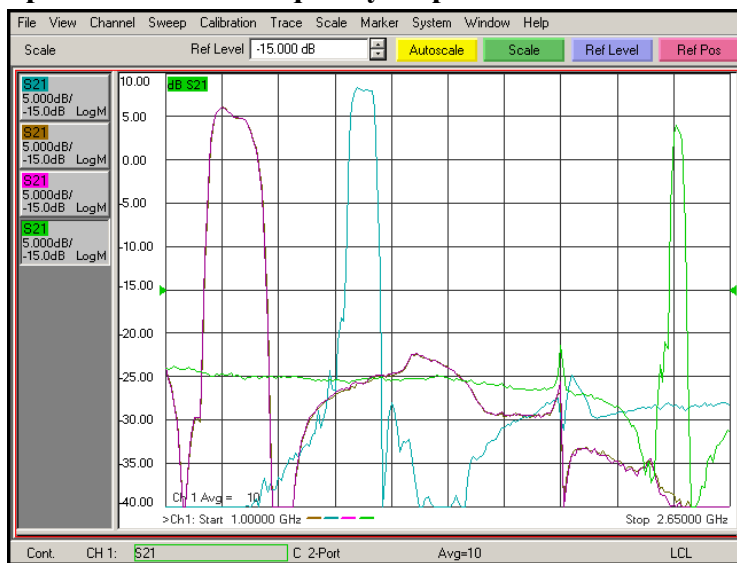

Splitter parameters:

Power gain, dB (typ)

Channel #1	8.0
Channel #2	5.0
Channel #3	5.0
Channel #4	4.0
Channel #5	8.0

Noise figure, dB (typ)

Channel #1	1.6
Channel #2	2.0
Channel #3	2.0
Channel #4	1.8
Channel #5	1.6

The following signals can be received with NT1068 IC:

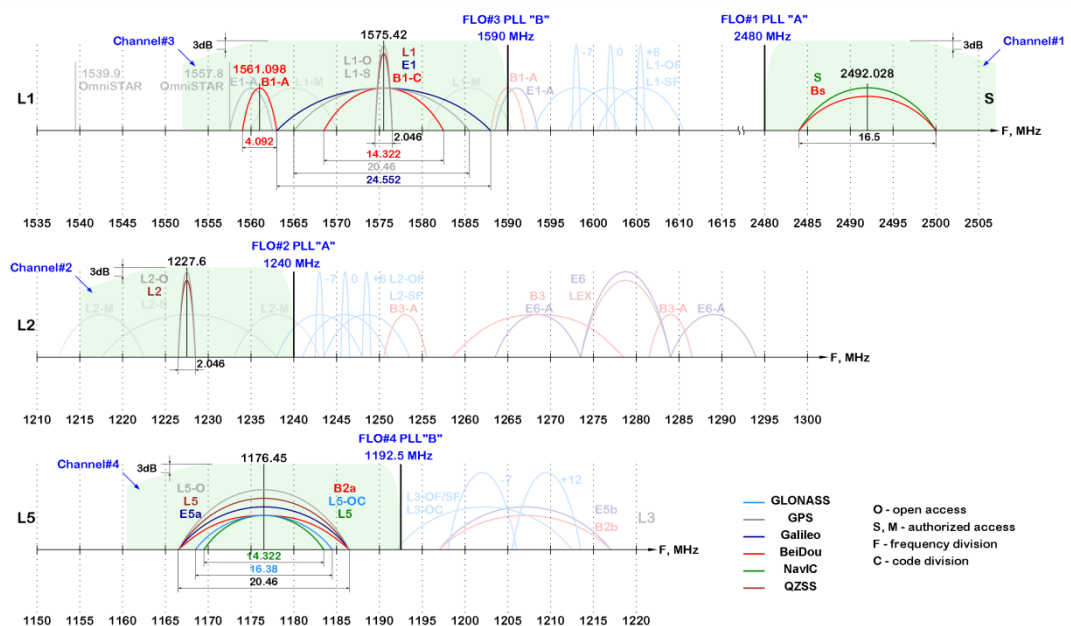

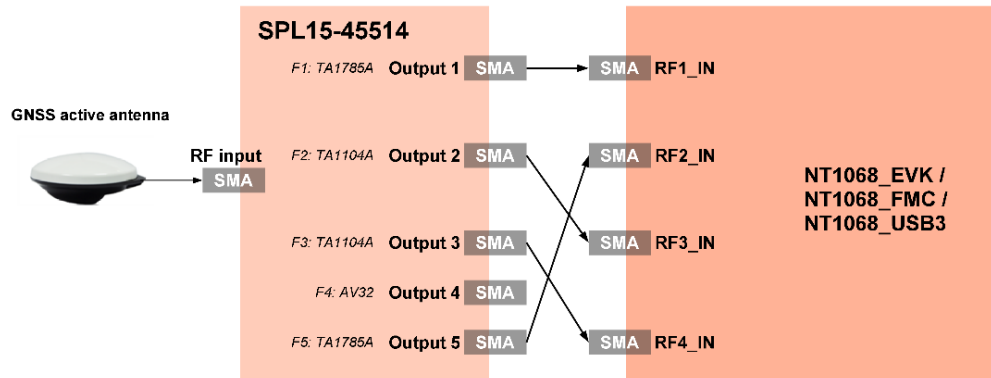

Splitter channels frequency response:

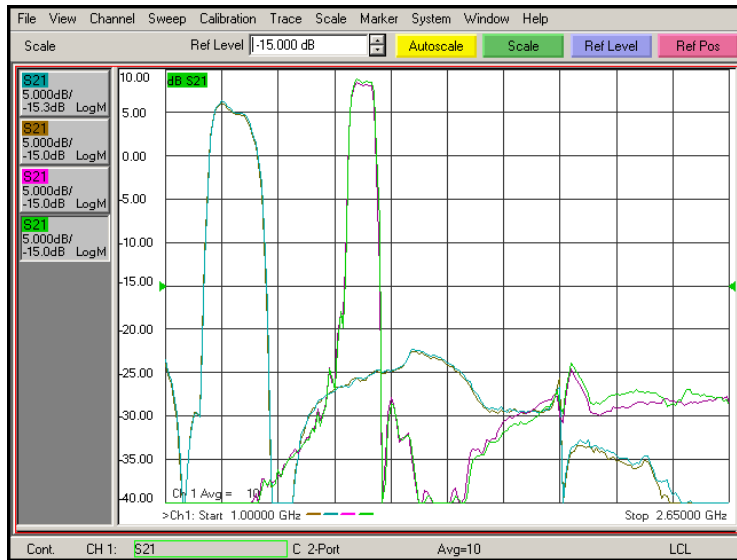

Splitter parameters:

Power gain, dB (typ)

Channel #1	8.0
Channel #2	5.0
Channel #3	5.0
Channel #4	4.0
Channel #5	8.0

Noise figure, dB (typ)

Channel #1	1.6
Channel #2	2.0
Channel #3	2.0
Channel #4	1.8
Channel #5	1.6

The following signals can be received with NT1068 IC:

1.

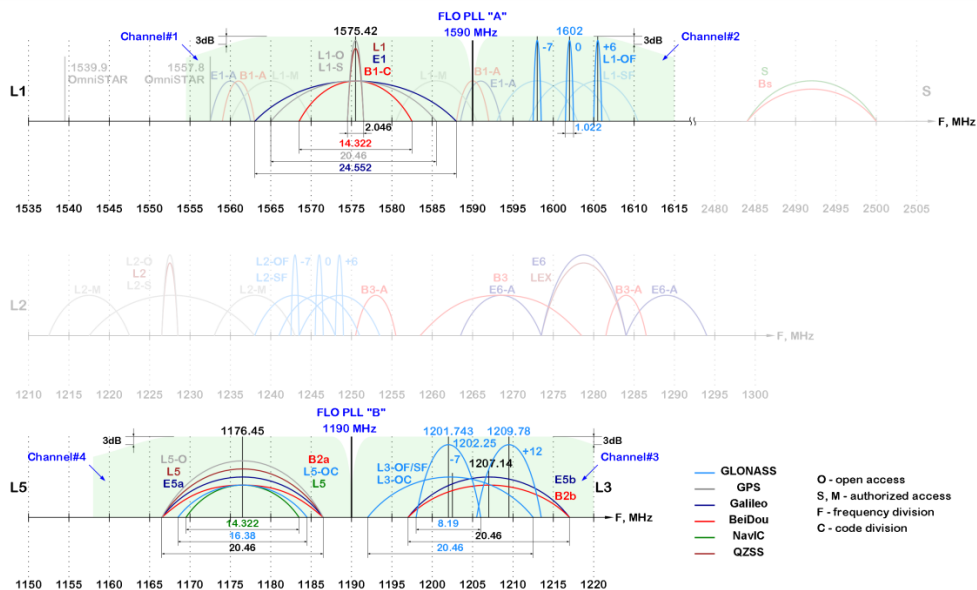

2.

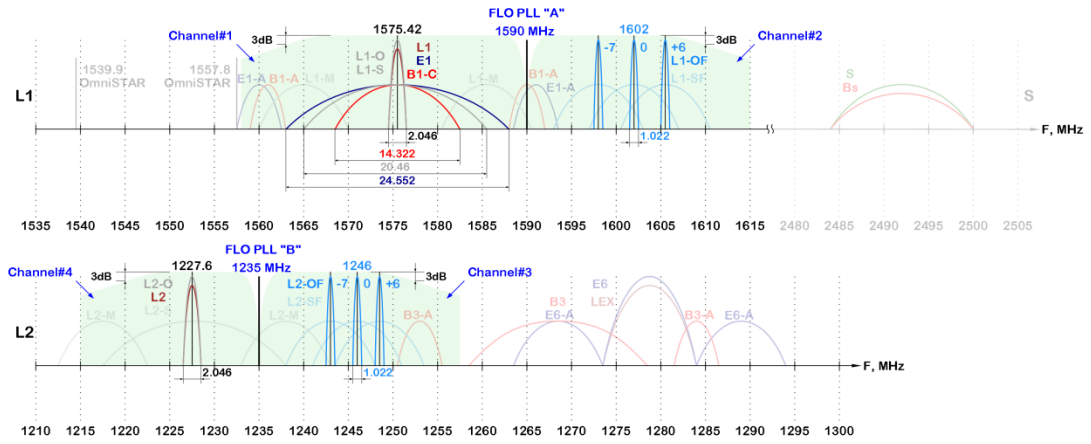

7.4. SPL15-465X5 & NT1068_EVK

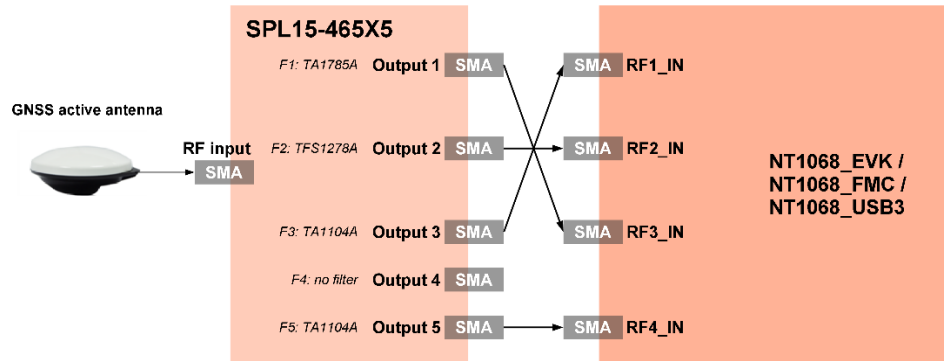

Splitter channels frequency response:

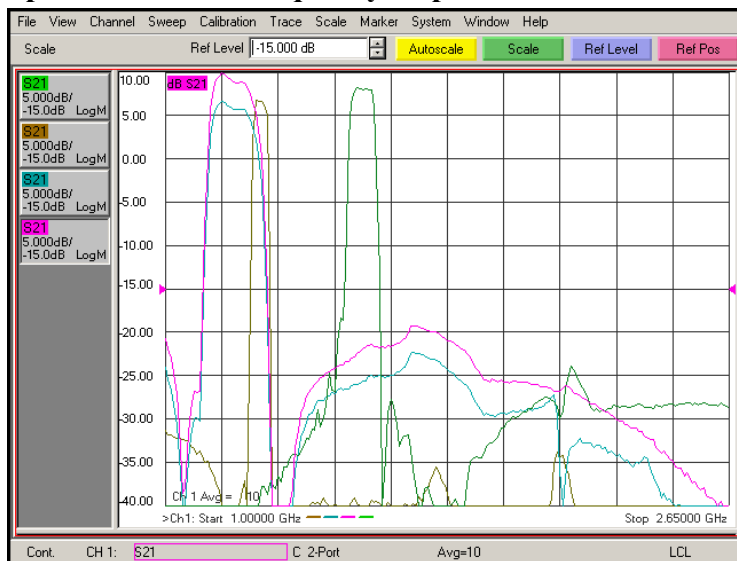

Splitter parameters:

Power gain, dB (typ)

Channel #1	8.0
Channel #2	6.5
Channel #3	5.0
Channel #4	6.0
Channel #5	9.0

Noise figure, dB (typ)

Channel #1	1.6
Channel #2	2.0
Channel #3	2.0
Channel #4	1.4
Channel #5	1.4

The following signals can be received with NT1068 IC:

